



— MODEL — **50B-5KG**

# Pump Suction Control Valve



50B-5KG



Sizes 3" - 8"

- Adjustable Opening Speed For Pump Suction Protection
- Pilot Control Provides Wide Flow Range With Minimal Pressure Variations
- Controlled Closing For System Protection
- Modulates Within 5% of Setting for Accurate Pressure Control
- Pressure Setting Adjustable
- Pressure Setting Not Affected by Pressure at Valve Discharge

The Model 50B-5KG Pump Suction Control Valve is designed specifically for Fire Pump Suction Control Service. It modulates to maintain the pump discharge in relation to the suction head available, thus assuring that the suction head pressure does not fall below the pre-set minimum. The 50B-5KG can be supplied with optional internal and external epoxy coating of the main valve wetted surfaces.

## Typical Installation

When there is a demand in the Fire System, the pump is started, delivering water from the supply source to the area of demand. To assure that the fire pump draw does not exceed the available water supply, the Model 50B-5KG, sensing the pump suction, modulates to prevent suction pressure from dropping below a pre-set minimum.

By maintaining minimum pressure requirements in the supply main, the main is protected from possible damage or backflow conditions. Also, a minimum supply pressure is provided for local fire apparatus.

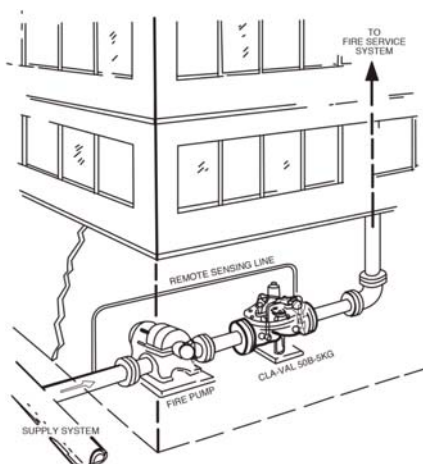

## Specifications

- Sizes** Globe: 3" - 10" flanged  
Angle: 3" - 10" flanged
- End Details** 150 and 300 ANSI B16.42
- Pressure Ratings** 150 class - 250 psi Max.  
300 class - 400 psi Max
- Temperature Range** Water, to +180°F Max.
- Materials** **Main valve body & cover**  
Ductile Iron ASTM A-536
- Main valve trim:**  
Brass QQ-B-626  
Bronze Seat ASTM B61  
Stainless Steel Stem 303  
Delrin Sleeved
- Pilot control system:**  
Cast Bronze ASTM B62 with  
303 Stainless Steel trim
- Adjustment Range** Available in the following pressure range only:  
5 to 25 psi  
Set at 10 psi

## Dimensions (in Inches)

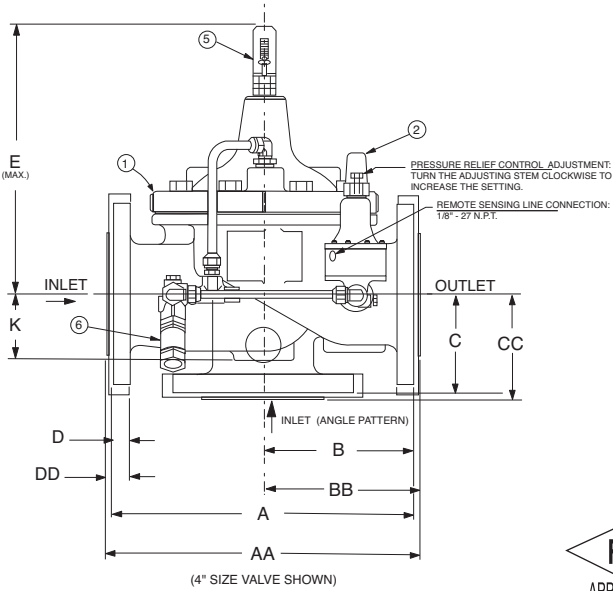

Item No.	Description
1	100KCGVX Hytrol (Main Valve)
2	CRL5A Pressure Relief Control
3	X44A Strainer and Orifice Assembly
4	CV Flow Control (Opening)
5	X101C Valve Position Indicator
6	CK2 (Blow-Off Valve)



## Flow Chart

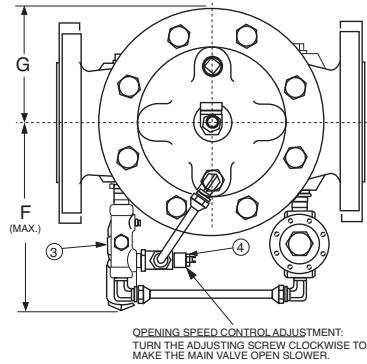
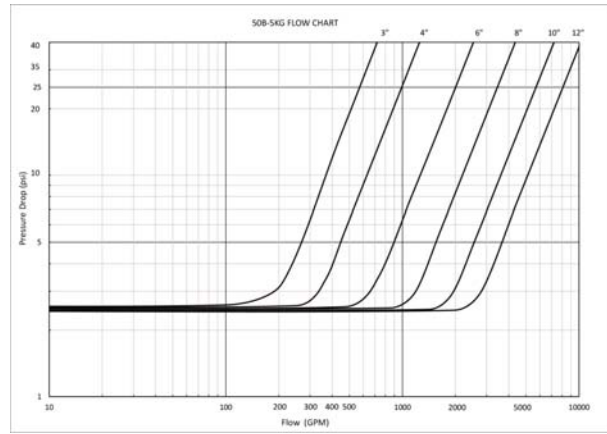

VALVE SIZE	A 150 LB. FLANGES	AA 300 LB. FLANGES	B 150 LB. FLANGES	BB 300 LB. FLANGES	C 150 LB. FLANGES	CC 300 LB. FLANGES	D (TYP.) 150 LB. FLANGES (MIN.)	DD (TYP.) 300 LB. FLANGES (MIN.)	E (MAX.)	F (MAX.)	G (MAX.)	K
3"	12.00	13.25	6.00	6.38	4.00	4.38	.75	1.12	15.75	13.50	4.62	2.56
4"	15.00	15.62	7.50	7.88	5.00	5.31	.94	1.25	17.75	15.00	5.75	3.19
6"	20.00	21.00	10.00	10.50	6.00	6.50	1.00	1.44	20.25	16.50	7.88	4.31
8"	25.38	26.38	12.75	13.25	8.00	8.50	1.12	1.62	23.00	20.00	10.00	5.31
10"	29.75	31.12	14.88	15.56	8.62	9.31	1.12	1.12			--	

**Note:**  
10" and 12" are not FM Approved but built to FM standard

## Purchase Specifications

The Fire Pump Suction Control Valve shall modulate to maintain a minimum pressure at the pump suction regardless of system demand. It shall control the pump discharge in relation to the suction head available, and shall not allow suction head pressure to fall below a pre-set minimum.

It shall be actuated by line pressure through a pilot control system which allows rapid response to changing pressure conditions without line surges. The pilot control shall be remote sensed to the pump suction head pressure.

The main valve shall be of the hydraulically-operated, pilot-controlled, diaphragm-type, globe or angle valve. It shall have a single removable seat, a delrin-sleeved guided stem and a renewable resilient synthetic rubber disc with a rectangular cross

section, contained on three and one-half sides by a disc retainer and disc guide. No external packing glands shall be permitted and the diaphragm shall not be used as a seating surface. The pilot control shall be a direct-acting, adjustable, spring-loaded, diaphragm-type valve designed for modulating service to permit flow when controlling pressure exceeds spring setting.

A device indicating the percent at which the valve is open or closed shall be supplied on the assembly, together with a sediment evacuator and dampening device.

The valve shall be designed to allow for repair and servicing without removing the valve body from the line.

The valve shall be Factory Mutual Approved. It shall be the MODEL 50B-5KG FIRE PUMP SUCTION CONTROL VALVE as manufactured by Cla-Val, Newport Beach, California.

## CLA-VAL

1701 Placentia Avenue • Costa Mesa CA 92627

800-942-6326 • Fax: 949-548-5441 • Web Site: [cla-val.com](http://cla-val.com) • E-mail: [info@cla-val.com](mailto:info@cla-val.com)



50B-5KG (R-04/2017)

**CLA-VAL CANADA**  
4687 Christie Drive  
Beamsville, Ontario  
Canada L0R 1B4  
Phone: 905-563-4963  
Fax: 905-563-4040  
E-mail: [sales@cla-val.ca](mailto:sales@cla-val.ca)

**CLA-VAL EUROPE**  
Chemin des Mésanges 1  
CH-1032 Romanel/  
Lausanne, Switzerland  
Phone: 41-21-643-15-55  
Fax: 41-21-643-15-50  
E-mail: [cla-val@cla-val.ch](mailto:cla-val@cla-val.ch)

**CLA-VAL UK**  
Dainton House, Goods Station Road  
Tunbridge Wells  
Kent TN11 2 DH England  
Phone: 44-1892-514-400  
Fax: 44-1892-543-423  
E-mail: [info@cla-val.co.uk](mailto:info@cla-val.co.uk)

**CLA-VAL FRANCE**  
Porte du Grand Lyon 1  
ZAC du Champ du Périer  
France - 01700 Neyron  
Phone: 33-4-72-25-92-93  
Fax: 33-4-72-25-04-17  
E-mail: [cla-val@cla-val.fr](mailto:cla-val@cla-val.fr)

**CLA-VAL PACIFIC**  
45 Kennaway Road  
Woolston, Christchurch, 8023  
New Zealand  
Phone: 64-39644860  
[www.cla-valpacific.com](http://www.cla-valpacific.com)  
E-mail: [info@cla-valpacific.com](mailto:info@cla-valpacific.com)