

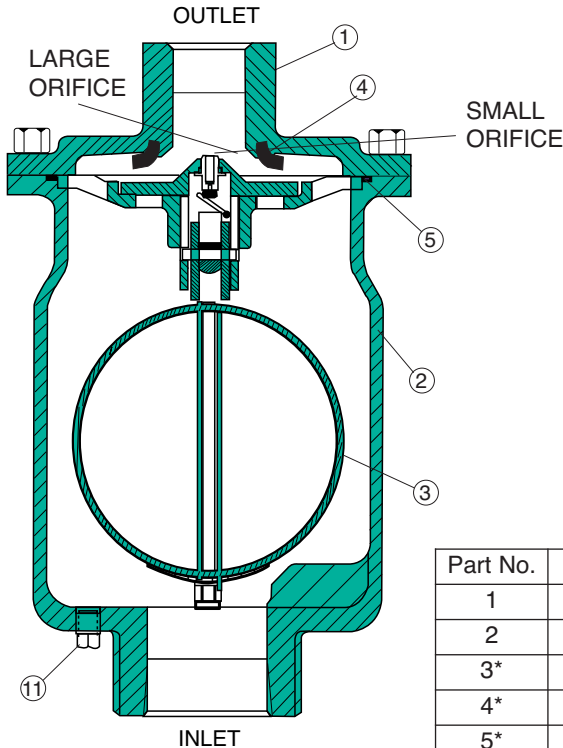

— MODEL — **33A**

# High Performance Combination Air Release & Vacuum Valve



1" 33A

### INTRODUCTION

Cla-Val Combination Air Valves have been designed with stainless steel trim to give years of trouble-free service. Combination Air Valves are typically installed at high points of a water piping system. They perform both functions of air release valve and air/vacuum valve in one body.

Combination Air Valves automatically vent pockets of air from high points while the system is pressurized. The valve will also vent and admit large volumes of air while or draining the system or during emergency power failure conditions. Both air release and air/vacuum functions are essential to maintain pipeline efficiency and protection from adverse pressure conditions.

### RECEIVING AND STORAGE

Inspect valves for damage upon receipt. Valves should remain boxed and stored in doors until installed to prevent weather related damage

Part No.	Qty.	Description	Part No.	Qty.	Description
1	1	1" Cover (33A)	7	8	Bolt Hex Nut (33A)
2	1	1" Body (33A)	8	2	Screw Drive
3*	1	1" Float Ball Assembly	9	1	Nameplate
4*	1	1" Seal Rign	10	1	O-Ring
5*	1	O-Ring (33A)	11	1	1/4" NPT Drain Plug
6*	1	1" Seat (33A)	*Recommended Spare Parts Kit		

### DESCRIPTION OF OPERATION

Combination Air Valves are fully automatic and designed to continuously remove pockets of air from high points in a piping system. They also vent and admit large volumes of air during filing or draining of the pipeline or tank. These are a normally open air valves that function in three ways:

1. During System start-up, the large open orifice exhausts large volumes of air until fluid enters the valve. Then the float rises to shut both the large orifice seat and the small orifice seat. Pressure within the valve will force the float tightly against both the seat orifices.
2. As air accumulates at the high points of the piping system, (where the valve is installed) air displacing the fluid, the float lowers with the fluid and breaks contact with the small orifice seat. Accumulated air in the valve, is then vented through the small orifice. As air is vented, the floats raise again and closes the small orifice. This sequence repeats automatically as air accumulates in the air valve.

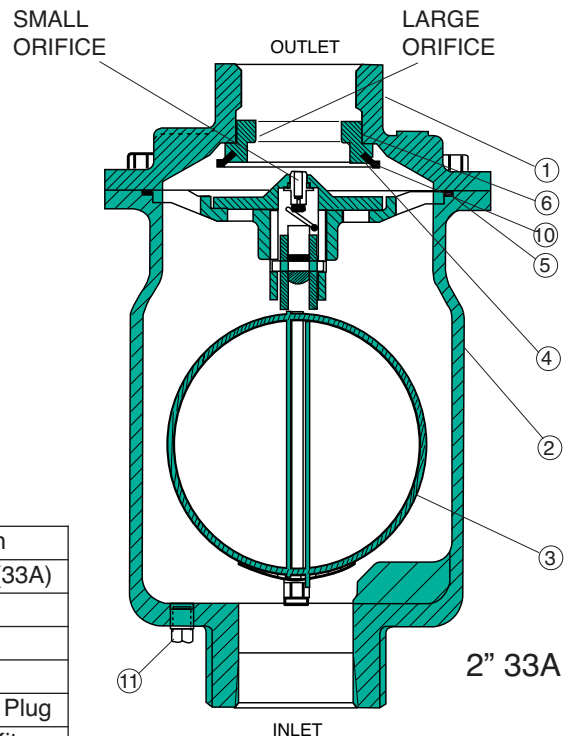

2" 33A

Part No.	Qty.	Description	Part No.	Qty.	Description
1	1	2" Cover (33A)	7	8	Bolt Hex Nut (33A)
2	1	2" Body (33A)	8	2	Screw Drive
3*	1	2" Float Ball Assembly	9	1	Nameplate
4*	1	2" Seal Rign	10	1	O-Ring
5*	1	O-Ring (33A)	11	1	1/4" NPT Drain Plug
6*	1	2" Seat (33A)	*Recommended Spare Parts Kit		

## Specifications

### MODEL 33A - 1",2",3" and 4" SIZES Single Body Combination Air Vacuum Air Release Valve

#### Pressure Ratings

500 psi Ductile Iron  
Body and Cover

500 psi Stainless Steel  
Body and Cover

600 psi Cast Steel  
Body and Cover

#### Materials

Body and Cover:  
Ductile Iron

ASTM A536 65-45-12

Body and Cover

Stainless Steel T303

Body and Cover

Cast Steel ASTM A 216 WCB

#### Note:

Readily available for seawater service and other  
corrosive fluids applications Made of:

Monel - Bronze's - Stainless Steel

#### Standard Internals

Float: Stainless Steel T304

Balance internals parts Stainless Steel and Delrin

Seals Nitrile Rubber or Viton (extra cost)

#### Temperature Range

Water to 180° F

#### Optional:

1. Fusion epoxy lined and coated at extra cost
2. For Well Service Install Throttling Device on the Outlet

#### PROBLEMS / SOLUTIONS

##### 1. Leakage at Inlet Connection:

Tighten valve threaded connection. If leaks persist, remove valve and seals threads with pipe sealant or tape.

##### 2. Leakage at Cover/Body joint:

Tighten bolts per Table 2, replace gasket.

##### 3. Small or Large Orifice Leakage:

Flush valve to remove debris. Disassemble and inspect both seat, orifices and float for wear or damage. Replace as needed with a float kit or seat kit

##### 4. Small Orifice not Releasing Air Under Pressure:

Check that operating pressure does not exceed Working Pressure on nameplate. Perform inspection step 3 and disassemble valve if problem persists.

#### DISASSEMBLY

The valve can be disassembled without removing it from the pipeline, or it may be removed from the line. All work on the valve should be performed by a skilled mechanic. Special tools are NOT required.

**CAUTION:** Drain the valve and de-pressurized before removing the cover or pressure may causing injury.

1. Close inlet shut-off valve. Slowly open drain valve or remove drain plug. Remove the covers bolts slowly.
2. Pry cover loose and lift off valve body.
3. Remove entire seat & float assemblies inspect for damage or wear
4. Clean and inspect parts. Note: Shake float & if water inside float replace it and worn parts as necessary.

**NOTE:** Float Kit & Seat Kit includes cover gasket

Valve Size	1"	2"	3"	4"
A	9.10	12.44	12.75	12.75
B	6.25	7.50	9.00	9.00
Inlet (NPT)	1" NPT	2" NPT	3" NPT	4" NPT
Outlet (NPT)	1" NPT	2" NPT	4" NPT	4" NPT
Shipping Wt. (Lbs.)*	25	29	38	40
Max. Operating PSI (Std. Orifice)	300	500	300	300
Max. Operating PSI (with .076 Orifice)	300	500	450	450

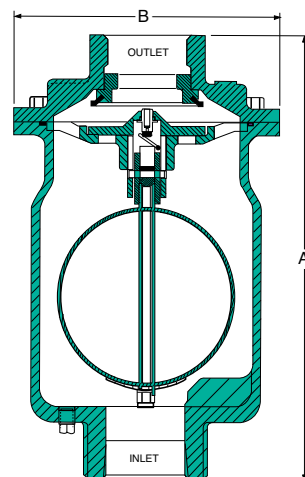

\* Approximate

Available Flanged

#### REASSEMBLY

1. All parts must be cleaned and gaskets surfaces cleaned with a stiff wire brush in the direction of the serration or machine marks. Worn parts, gaskets and seal should be replaced during reassembly.
2. Apply Loctite or similar Compound to threaded Connections
3. Stand valve body vertically. Insert entire delrin frame, seat & float assembly into register. Move float up/down to insure concentricity and no binding.
4. Lay new cover gasket on clean surface and apply a gasket compound such as Permatex #80065 to both surfaces. Assemble gasket and cover over bolt holes in body.
5. Insert lubricated bolts and tighten to the torques listed in Table 2.
6. Place valve back in service. Refer to the installation instruction. Slowly open inlet isolation valve.

**TABLE 2. VALVE COVER BOLT TORQUES**

BOLT SIZE	TORQUE (FT. LBS.)
1/4"-20	6
5/16"-18	11
3/8"-24	19
7/16"-32	30

#### PARTS AND SERVICE

Parts and service are available from your local representative or the factory. Make note of the valve Model No. and Working Pressure located on the valve nameplate.